



Facilities Standard

Document ID: PEL-E-260555 [PMO.DT-ST-04]

Circuit Numbering and Labeling for Electrical Equipment

Revision 7

Issued March 15, 2023

IM Release No. LLNL-MI-823076

Summary This standard describes requirements for numbering and labeling of real property electrical distribution equipment, circuits, and site lighting at Lawrence Livermore National Laboratory.

SME Anthony Nguyen

Approved Anthony Nguyen, IEOD Engineering Services Division Lead, Infrastructure and Engineering Operations

DocuSigned by:

 April 4, 2023
 33431A4CED38400...

Issued Jeff Clukey, Technical and Professional Services Lead
 Project Management Office

DocuSigned by:

 April 6, 2023
 BA6710CD320A493...

Note to Non-LLNL Architects/Engineers:

This is an internal LLNL standard meant to guide the design of new facilities, facility modifications, and maintenance. Wherever this standard mentions to confer with departments within LLNL, direct your inquiries to the Subcontract Technical Representative.

15 March 2023

LLNL-MI-823076

CHANGE HISTORY

Revision	Date	Previous	Revised
5	6/3/2021	Panelboard and Circuit Numbering	Electrical Equipment and Circuit Numbering and Labeling
5	6/3/2021		Revised in whole.
6	5/25/2022	Documentation and Technical Services Manager	Technical and Professional Service Manager
6	6/15/2022	--	Temporary equipment labels
6	6/3/2022	Subject Matter Expert: Russ Moder	Subject Matter Expert: Anthony Nguyen
6	6/3/2022	Approver: Kent Harrison	Approver: Anthony Nguyen <i>IEOD Engineering Services Division Lead</i>
7	3/15/2023	--	Added section 2.10 Site Lighting Numbering

15 March 2023

LLNL-MI-823076

TABLE OF CONTENTS

1	General	5
1.1	Purpose.....	5
1.2	Definitions and Abbreviations.....	5
1.3	References.....	5
2	Equipment Numbering	6
2.1	General.....	6
2.2	Illustration of Numbering.....	8
2.3	Illustration of Numbering for Modifications/Changes to Existing Systems.....	11
2.4	Transformer Numbering.....	15
2.5	Panelboard Circuit Breaker Numbering.....	16
2.6	Load Center.....	19
2.7	Motor Control Center Numbering.....	19
2.8	Large Panelboard, Switchboard, and Switchgear Numbering.....	21
2.9	Plug-In Bus Duct Numbering.....	22
2.10	Site Lighting Numbering.....	23
3	Equipment Labeling	24
3.1	General.....	24
3.2	Switchgear, Switchboards, Panelboards, Motor Control Centers, Distribution Panels, and Emergency Power Panels:.....	25
3.3	Low-Voltage Transformers.....	27
3.4	High-Voltage Transformers.....	28
3.5	Receptacles, switches, and outlets.....	28
3.6	Utilization Equipment.....	29
3.7	Mechanical Equipment.....	29
3.8	Electrical hazard (arc flash and shock) warning labels.....	29
3.9	Clear Working Space Labels.....	30
4	Scheduling	31
4.1	General.....	31
4.2	Schedule Changes.....	32
4.3	Schedule Implementation.....	33

TABLE OF FIGURES

Figure 1.	Process for numbering and labeling equipment.....	7
Figure 2.	Typical one-line diagram with labels.....	9
Figure 3.	Substation one-line diagram.....	10
Figure 4.	One-line diagram for multiple panels fed from a single transformer.....	12

15 March 2023

LLNL-MI-823076

Figure 5. Transformer addition without a bus tie.	13
Figure 6. Limited power supply.....	14
Figure 7. Unlimited power supply.....	15
Figure 8. Numbering scheme for 1-, 2-, and 3-pole breakers (sample). *2-pole breaker in 2-pole frame. Position of handle is dependent on circuit breaker manufacturer. Indicate circuit number wherever handle appears. **2-pole breaker in 3-pole frame. Position of handle is similarly dependent on circuit manufacturer.	17
Figure 9. Existing condition with skipped circuit numbers (non-standard).....	18
Figure 10. New numbers when replacing 3-pole breaker with three 1-pole breakers (non-standard)....	18
Figure 11. 10-circuit load center schedule.....	19
Figure 12. Motor control center.....	20
Figure 13. Switchgear	22
Figure 14. Plug-in bus duct.....	23
Figure 15. Site lighting label (horizontal label above, vertical option shown at right). Horizontal label is 1/2-inch-high yellow letters on a 2-inch-high by 7-inch-wide black background (example is approximately 1/2 scale).....	24
Figure 16. Distribution panel with main power source entry plate/label; 7/8-inch-high yellow letters on 4-inch high by 7-inch-wide black background (figure is approximately 1/2 scale).....	26
Figure 17. Distribution panel with main emergency power source entry plate/label; 7/8-inch-high black letters on 4-inch-high by 7-inch-wide yellow background (figure is approximately 1/2 scale).....	26
Figure 18. Load center panel plate/label with 1/2-inch-high yellow letters on a 2-inch-high by 7-inch-wide black background (figure is approximately 1/2 scale).	27
Figure 19. Distribution panel providing emergency uninterruptable power source (UPS) entry plate/label; 7/8-inch-high white letters on 4-inch-high by 7-inch-wide blue background (figure is approximately 1/2 scale).....	27
Figure 20. Transformer plate/label; 7/8-inch-high yellow letters on 4-inch high by 9-inch-wide black background (figure is approximately 1/2 scale). I&O is responsible for labeling high-voltage transformers (TH).	28
Figure 21. High-voltage transformer label.....	28
Figure 22. Arc flash and shock risk warning label.	30
Figure 23. Electrical panel clearance label.....	30
Figure 24. Completed panelboard schedule, typical.....	32

15 March 2023

LLNL-MI-823076

1 GENERAL

1.1 Purpose

Lawrence Livermore National Laboratory (LLNL) has a standardized system for numbering and labeling electrical equipment and circuits. This system establishes a unique identification number for each item, which avoids confusion and permits computerized processing of inventory, preventive maintenance, and operational data.

Follow this standard for all electrical equipment.

1.2 Definitions and Abbreviations

1.2.1 Abbreviations

BEAHJ: Building Electrical Authority Having Jurisdiction

CMSG: Configuration Management Service Group, I&O directorate (see also 1.2.2 Definitions)

DTS: Documentation and Technical Services group, O&B Project Management Office

FPOC: facility point of contact

I&O: Infrastructure and Operations directorate, Operations & Business

1.2.2 Definitions

I&O Electric Shop: Infrastructure and Operations directorate, Infrastructure Maintenance and Utilities Department (IMUD), Maintenance Production division.

configuration management: Infrastructure and Operations directorate, Infrastructure Engineering and Operations Department (IEOD), Technical Asset Management division, Configuration Management Service group.

primary side: The winding on the energy input side of the equipment.

secondary side: The energy output side of the equipment.

1.3 References

1.3.1 Lawrence Livermore National Laboratory (LLNL)

Environment, Safety, & Health Manual, Document 16.1, “Electrical Safety Program,” <https://esh-int.llnl.gov/man/16.1.pdf>

PMO.DT-ST-04, *LLNL Facilities Standards*, PEL-M-230550, "Equipment Numbering,"

<https://doellnl.sharepoint.com/teams/OBPMOEDMS/layouts/15/DocIdReDir.aspx?ID=OBPMOEDMS-3110600-271>

1.3.2 National Fire Protection Association (NFPA), NFPA 70, *National Electrical Code* (NEC)

2 EQUIPMENT NUMBERING

2.1 General

2.1.1 The LLNL system for numbering circuits designates a unique number that becomes the prime number for panelboard and circuit identification. This is supplemental to the requirements of NFPA 70, *National Electrical Code* (refer to "Identification" in the NFPA 70 index).

2.1.2 The Infrastructure and Operations directorate, Infrastructure Engineering & Operations department, principal low-voltage systems engineer is the building electrical authority having jurisdiction (BEAHJ) for the content of this standard. Contact the BEAHJ for guidance and questions at (925) 423-9294.

2.1.3 The Configuration Management Service Group (CMSG) assigns transformer and unit substation numbers. Refer to paragraph 2.4 Transformer Numbering for information on the numbering scheme.

2.1.4 The CMSG manages three areas of electrical system documentation on the secondary (energy output) side of transformers and unit substations: (1) electrical one-line diagrams, (2) electrical panel location drawings, and (3) electrical panel schedules. Changes to documentation, whether through projects or maintenance work, follow the process shown in figure 1.

2.1.4.1 The initiating organization (IO) may be any group at LLNL that is engaged in site or facility construction projects, equipment maintenance, or facility management; or it may be an external subcontractor executing a project. If the IO is external, the subcontract technical representative (STR) collects and distributes documents to CMSG on behalf of the IO.

2.1.4.2 CMSG field coordinators physically verify the correctness of equipment and electrical panel locations, confirm database information, and place the appropriate labels and tags.

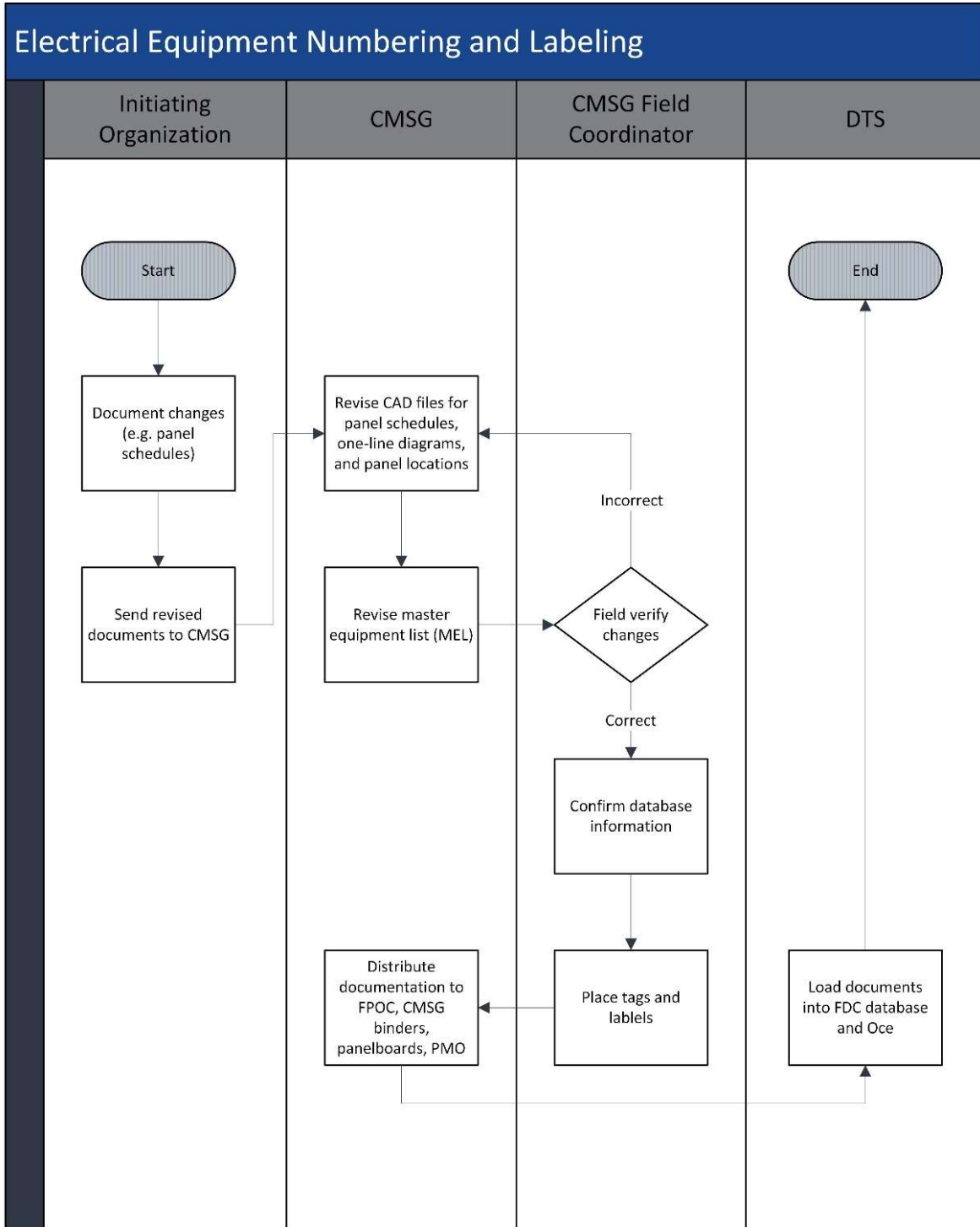

Figure 1. Process for numbering and labeling equipment.

15 March 2023

LLNL-MI-823076

2.2 Illustration of Numbering

2.2.1 The one-line diagram shown in figure 2 is a typical distribution configuration found in LLNL facilities and illustrates the numbering system. The following paragraphs describe the configuration.

2.2.1.1 A 13.8 kV-480/277 V transformer (labeled T0065) supplies power to a main panel (labeled 65A). Circuit breaker 3 in panel 65A services distribution transformer T0066 (480-208/120 V) and panel 66A.

2.2.1.2 Circuit 9 in panel 65A feeds a single panel. This panel is labeled 65A9.

2.2.1.3 Circuit 4 in panel 65A feeds emergency panels via an automatic transfer switch (ATS). When an outage occurs, the transfer switch allows the emergency generator to provide power to emergency panel E65A4.

2.2.1.4 Circuit 10 in panel E65A4 feeds 480 V to the primary side of a dry-type transformer, TE0067. The secondary side supplies 208/120 V to the main breaker of panel E67A.

15 March 2023

LLNL-MI-823076

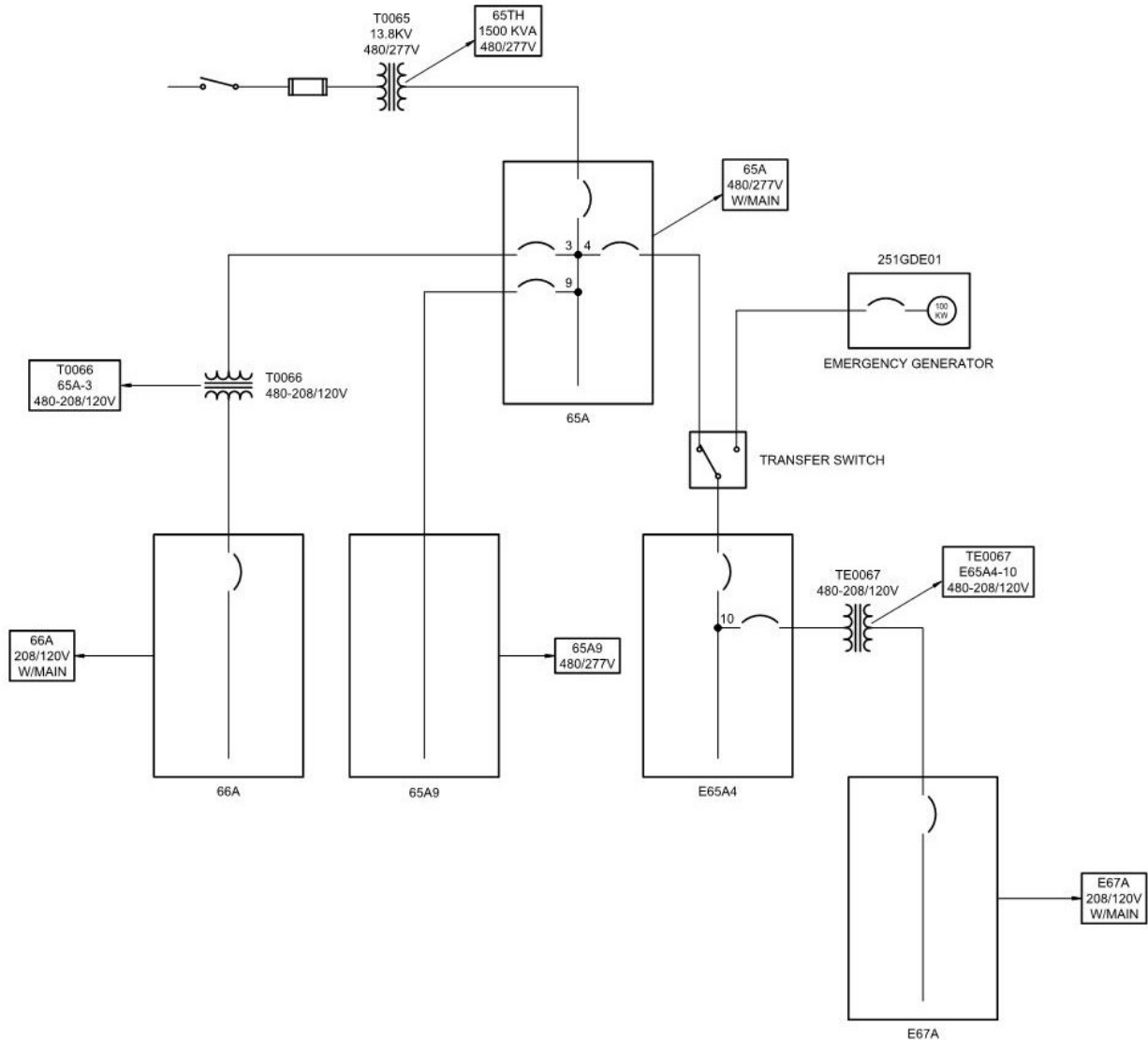

Figure 2. Typical one-line diagram with labels.

2.2.2 The one-line diagram shown in figure 3 is typical of a substation and illustrates the numbering system. The following paragraphs describe the configuration.

2.2.2.1 Circuit 1 in panel 65A feeds loads of two separate locations in an area or increment of a building. Each panelboard is considered a main and takes the number switchgear appended by the feeder number and a sequential letter (e.g., A, B, C); in this case, 65A1A and 65A1B.

2.2.2.2 Circuit 2 in panel 65A feeds a panel that serves both a step-down transformer and emergency panels (via an ATS). Each transformer bank is assigned an incremental number as shown in figure 3. These

transformer numbers become the prime numbers for the 208/120 V panelboards, in this case 66A and E67A.

2.2.2.3 Circuit 6 in panel 65A feeds a motor control center that serves a group of motors. The letters "MCC" preceding the motor control center number simplifies identification circuit checking.

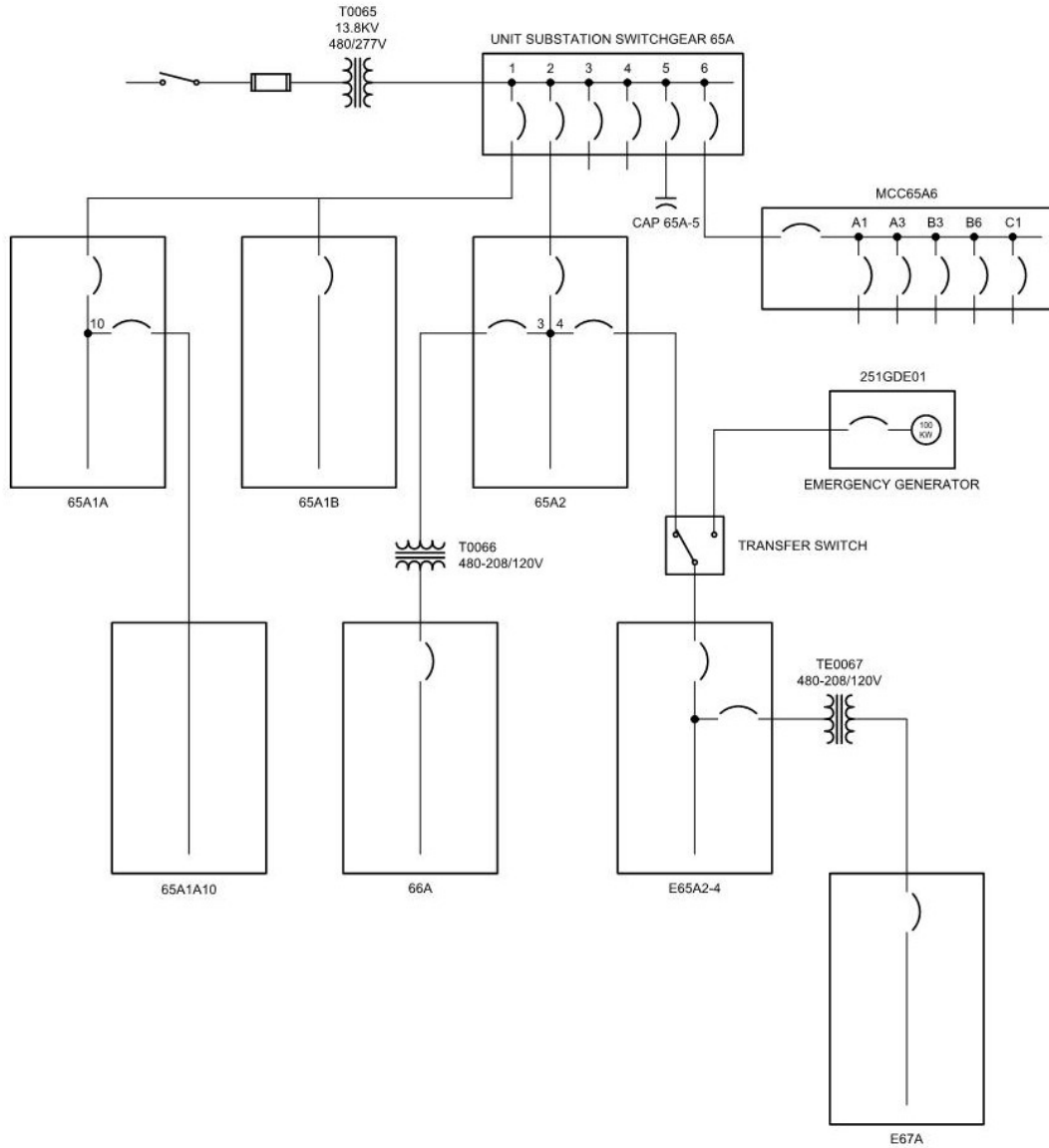

Figure 3. Substation one-line diagram.

15 March 2023

LLNL-MI-823076

2.2.3 Note that there is a different designation for a feeder to a panel than for a feeder to a final load, such as an outlet or a motor. The designation for a panel would be 65A2, while a circuit going to an end device would be designated 65A-2. The use of the dash mark designates the final load. Separate multiple alphabetical or numerical numbers by a dash to preserve identity (i.e., 65A2-3-25), even if serving a distribution panel.

2.3 Illustration of Numbering for Modifications/Changes to Existing Systems

2.3.1 Comply with this standard for equipment numbering and labeling changes that occur as a result of modifications. Replace panel labels to reflect connected load changes (i.e., air conditioning units, heaters, receptacles, and like items).

2.3.2 Projects involving additions and changes to the low-voltage electrical system are responsible for identifying circuit changes downstream of the affected panels. This entails revising one-line diagrams, electrical location drawings, and panel schedules and sending the updated documents to the CMSG.

2.3.3 Figure 4 shows an example of two panels fed from a common transformer where one panel is replaced in the building. The following paragraphs describe the numbering logic.

2.3.3.1 Panel 10A feeder is re-routed from the transformer and into panel 10B.

2.3.3.2 All equipment associated with panel 10A is then relabeled to reflect the new panel number. As shown below, panel 10A becomes panel 10B4.

2.3.3.3 The designator “B” will remain with panel 10B even though T0010 only feeds one panel. This is to prevent inconsistencies with the existing equipment labeling of existing panel 10B.

15 March 2023

LLNL-MI-823076

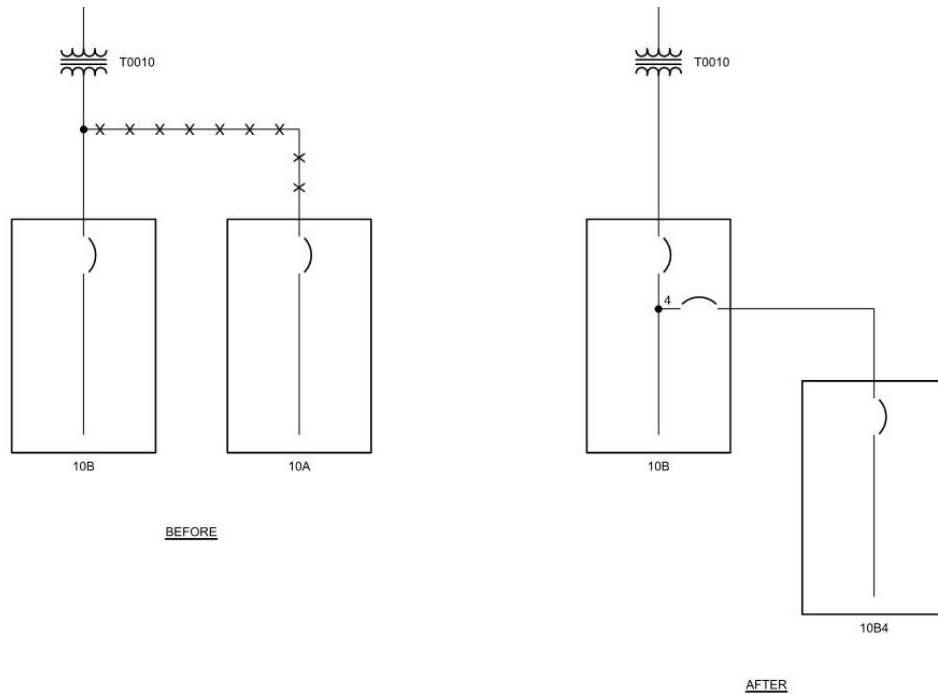

Figure 4. One-line diagram for multiple panels fed from a single transformer.

2.3.4 Reflect changes in a source transformer number in the downstream panel numbers and each load label to reflect. Reflect changes in a panelboard source (e.g., circuit breaker number) in downstream panelboards and associated load labels. See figure 5 for an illustration of labeling when adding a transformer. Numbers will not change if the transformer is replaced because the new transformer will take the old number. The labels may change, however, if the switchgear arrangement requires new numbers.

2.3.5 UPS-Supplied Equipment With Limited (Uninterruptible) Power Supply: An uninterruptible power supply (UPS) battery system provides continuous power through an outage for a limited amount of time, until the UPS batteries are discharged. Limited UPS power supply panels, circuits, and equipment are denoted with the prefix “LU” as shown in figure 6.

2.3.6 Unlimited (Uninterruptible) Power Supply: An emergency generator provides backup to a limited (UPS) power source which provides continuous power through an outage indefinitely. The circuit number will indicate "unlimited" (EU instead of LU). Similarly, transformers being fed from this system will be designated “TEU” as shown in figure 7.

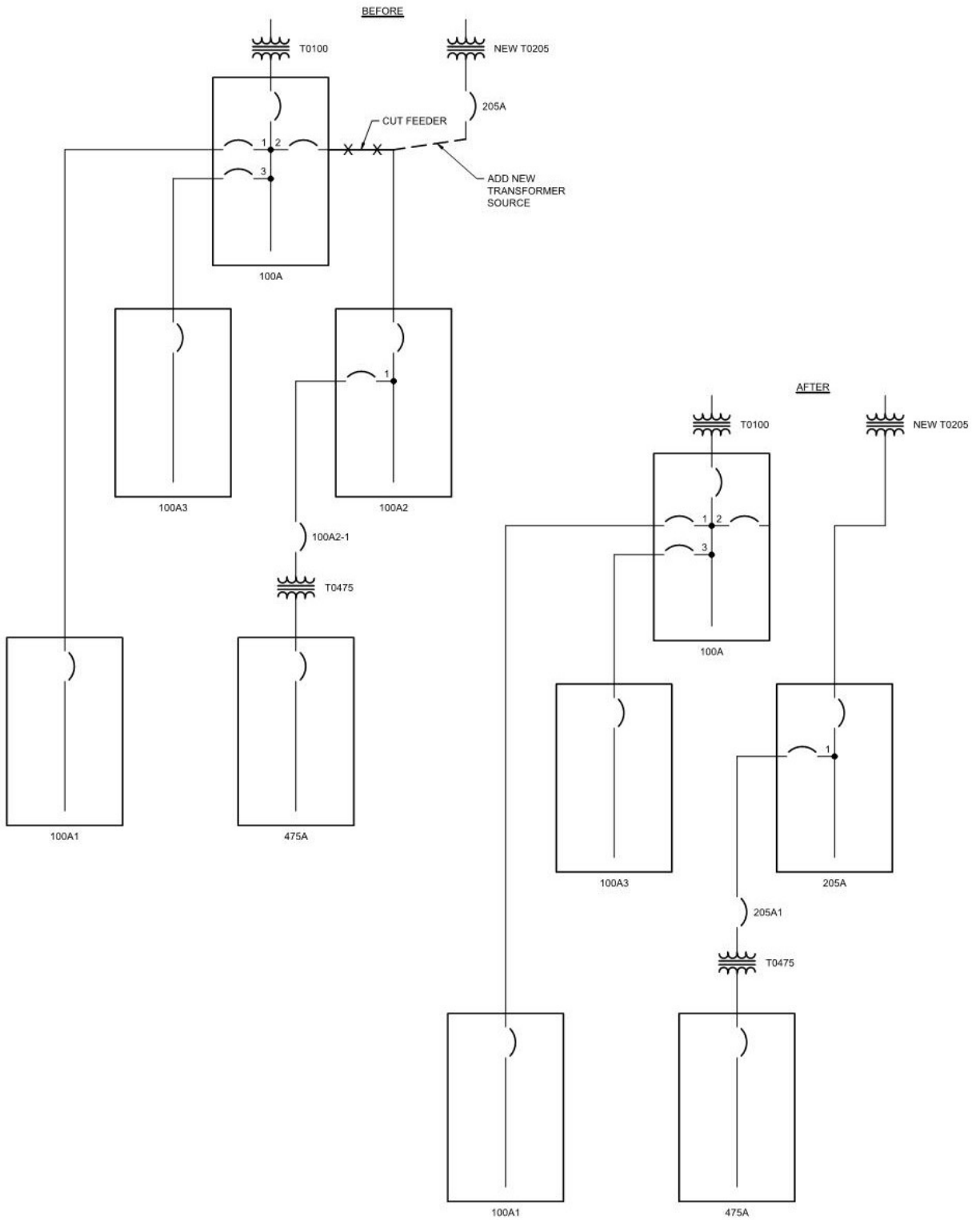

Figure 5. Transformer addition without a bus tie.

15 March 2023

LLNL-MI-823076

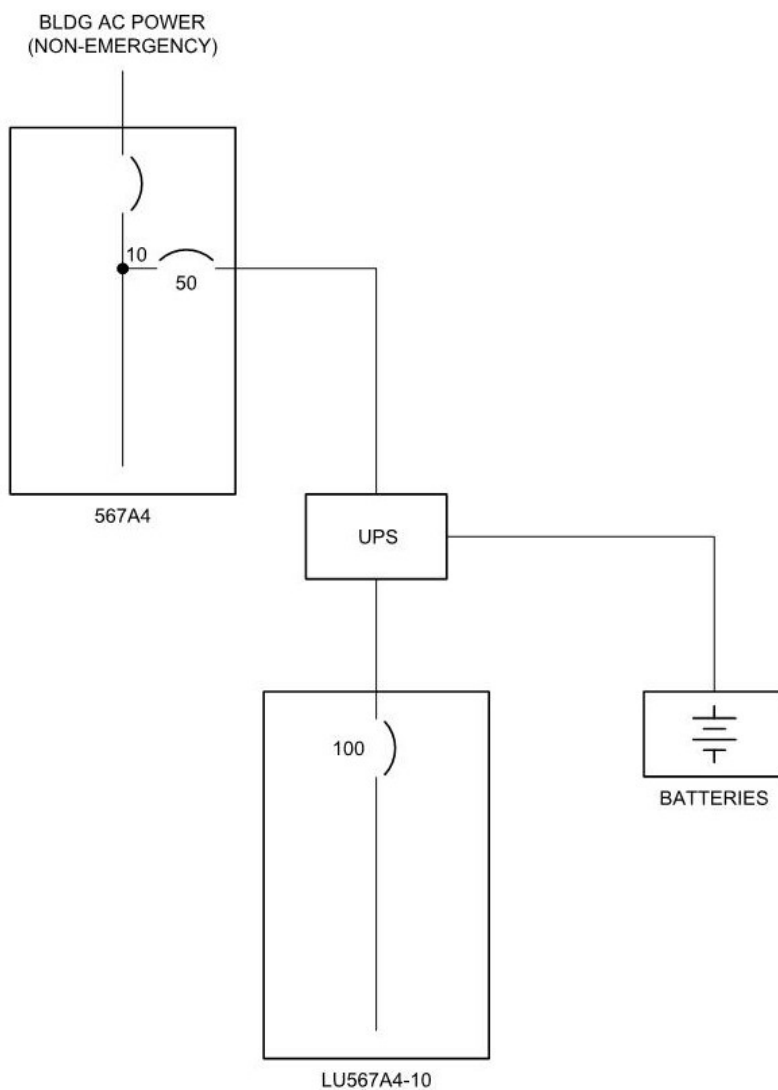

Figure 6. Limited power supply

15 March 2023

LLNL-MI-823076

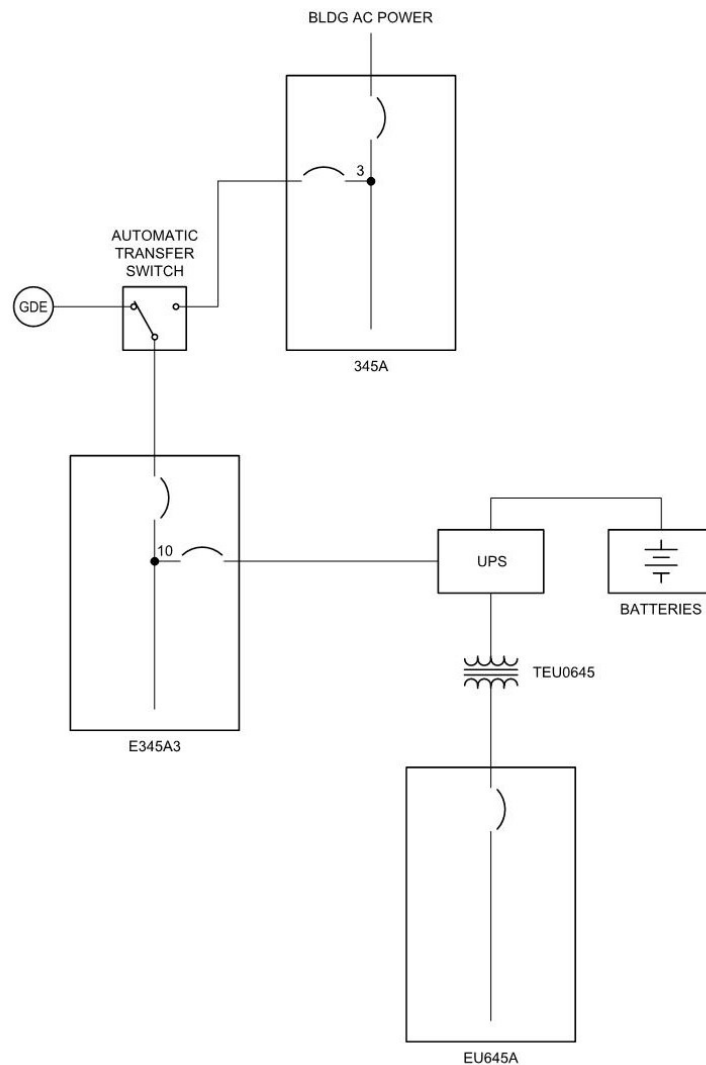

Figure 7. Unlimited power supply

2.4 Transformer Numbering

2.4.1 The CMSG field coordinators assign both high-voltage (HV) and low-voltage (LV) transformer numbers for site 200 and 300.

2.4.2 Low-voltage transformer numbers consist of a four-digit number (assigned by CMSG) preceded by one of the following letter designations:

T	=	Transformer
TE	=	Transformer, Emergency
TER	=	Transformer, Emergency Regulated Power
TEU	=	Transformer, Emergency Uninterruptible Power Supply (UPS)
TLU	=	Transformer, Limited Uninterruptible Power Supply (UPS)

15 March 2023

LLNL-MI-823076

2.4.3 High voltage transformers (12 kV and 13.8 kV) consist of a four-digit number (assigned by CMSG) followed by “TH.”

Note: Some older transformers do not comply with this standard. Consult with CMSG for further information.

2.5 Panelboard Circuit Breaker Numbering

2.5.1 Assign a number to unit spaces in the panelboard based on the smallest single-pole breaker that may be used in that panelboard. This permits circuitry changes within the panelboard affecting only the numbering of the circuit breakers occupying the unit spaces involved. Refer to figure 8. For 3-pole breakers, the middle unit space becomes the breaker number. With 2-pole breakers, the top unit space becomes the breaker number for breakers mounted on the left side of the panelboard, and the bottom unit space becomes the breaker number for breakers mounted on the right side of the panelboard. Some 2-pole models use a 3-pole space frame with no circuit in the middle space. The operating handle, however, is in the middle and is labeled with that space number. Number designation is from left to right and top to bottom, odd on the left, even numbers on the right. In main breaker panels do not number the main breaker.

2.5.2 See figure 9 for an example of a legacy panelboard schedule with skipped circuit numbers.

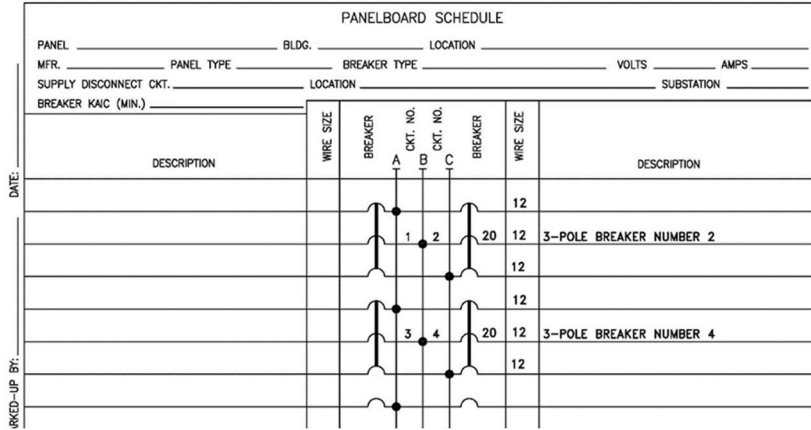

Figure 9. Existing condition with skipped circuit numbers (non-standard).

2.5.3 Where 3-pole breakers are replaced with three 1-pole breakers and only one number was previously assigned (in error), maintain that circuit number with “A”, “B”, and “C” suffixes. Refer to figure 10. Do not follow this direction when three numbers have been previously assigned (correct procedure).

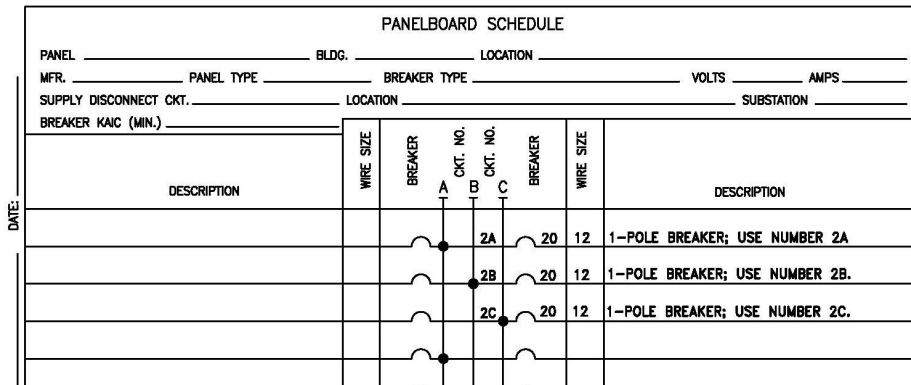

Figure 10. New numbers when replacing 3-pole breaker with three 1-pole breakers (non-standard).

2.6 Load Center

2.6.1 See figure 11 for proper method of numbering circuits in a load center. Begin load center number with "LC" designator.

LOAD CENTER SCHEDULE				
LOAD CENTER LC131A15		BLDG. _____	LOCATION _____	
MFR. _____	PANEL TYPE _____	BREAKER TYPE _____	VOLTS _____	AMPS _____
SUPPLY DISCONNECT CKT. _____		LOCATION _____	SUBSTATION _____	
		BREAKER KAIC (MIN.) _____		
CKT. NO.	BREAKER	WIRE SIZE	DESCRIPTION	
		12	3-POLE BREAKER. NUMBERS 1 AND 3 ARE NOT LABELED. LABEL NUMBER 2.	
		12	1-POLE BREAKER. USE NUMBER 4.	
		12	1-POLE BREAKER. USE NUMBER 5.	
		12	2-POLE BREAKER. NUMBER 6 ALIGNS WITH THE OPERATING HANDLE. NUMBER 7 NOT LABELED.	
		12	2-POLE BREAKER IN 3-POLE FRAME. NUMBER 9 ALIGNS WITH THE OPERATING HANDLE. NUMBERS 8 AND 10 ARE NOT LABELED.	

BUS ENTRY _____	CONNECTED LOAD	ARC FLASH CATEGORY	FEEDER SIZE	REVISION SUBMITTED BY:
FDR. BREAKER _____	PHASE "A" _____ kW	_____	WIRE _____	_____
DATE INST. _____	PHASE "B" _____ kW		NEUT. _____	J.O./W.T. _____
LAST PM DATE: _____	PHASE "C" _____ kW		GND. _____	CAD REV. BY _____
			CONDUIT _____	CAD REV. DATE _____

Figure 11. 10-circuit load center schedule.

2.7 Motor Control Center Numbering

Figure 12 shows the numbering of circuits for a motor control center. Vertical sections are assigned letters from left to right, regardless of where the power enters the MCC. Distribution

bucket positions are assigned numbers from top to bottom based upon the smallest available bucket size. This method results in a number/letter grid position for each possible bucket arrangement. In the example, the numbering in each vertical section is from one up, depending on compartment size. In actual practice, the number of minimum-sized compartments that would fit in a vertical section would govern the maximum number. Where two disconnects are mounted in a single bucket use the notation A and B for the left and right disconnects, respectively. For example, MCC780C1B would be the right disconnect in a bucket that contains two circuit breakers.

Label with "MCC" followed by the number.

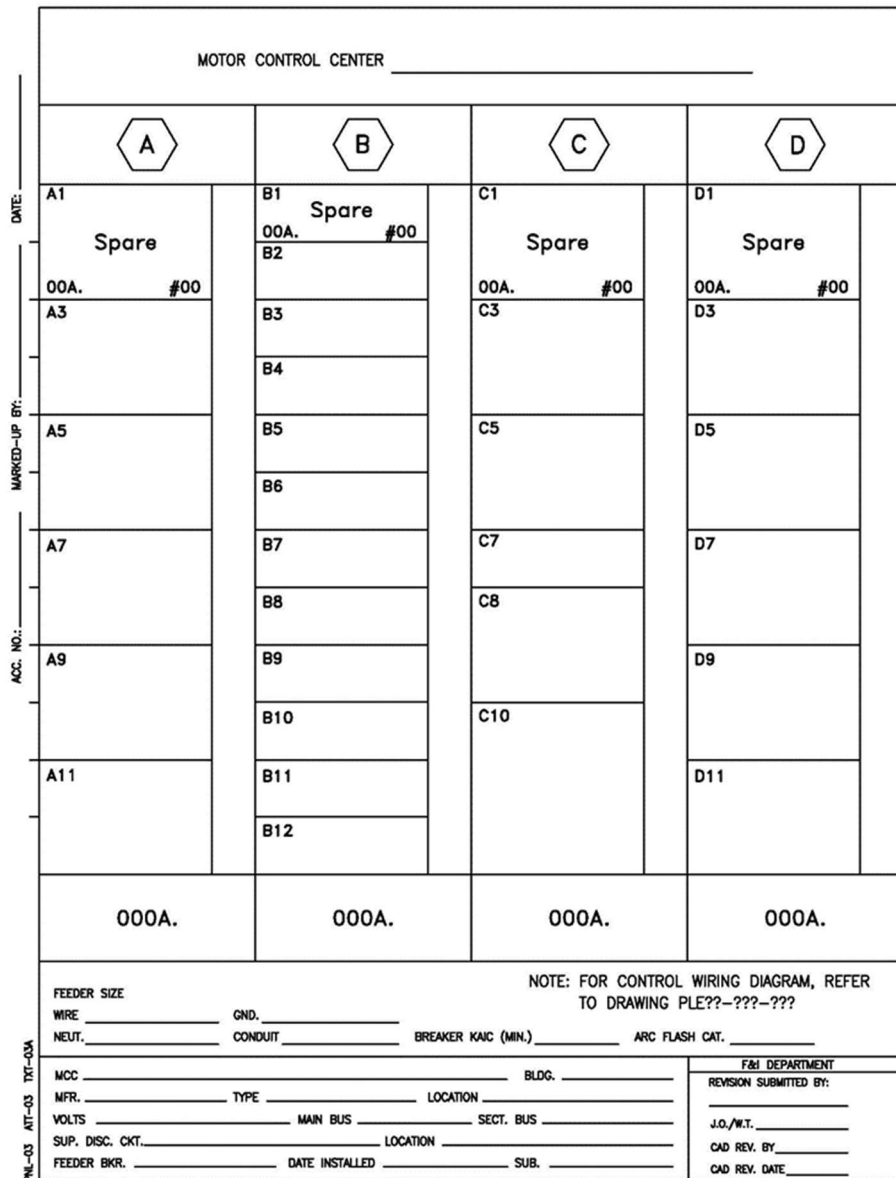

Figure 12. Motor control center

15 March 2023

LLNL-MI-823076

2.8 Large Panelboard, Switchboard, and Switchgear Numbering

Switchboards and switchgear are labeled using a grid system similar to MCCs, except that vertical sections are labeled with letters based upon the position relative to the main breaker.

- Left to right when there is no main breaker, or the main breaker is on the left
- Right to left when the main breaker is on the right.
- For other situations, contact the BEAHJ.

Numbering in each verticle section is from one up based upon the smallest frame size circuit breaker that can be installed.

1655			1654			
1655 METERS	A1 SPACE	B1 SPARE 1600A	CONTROL COMPARTMENT	B1 PNL. 1654B1 BLDG. 998 RM.2020 1000A	A1 SPACE	1654 METERS
	A2 PNL. 1655A2 BLDG. 999 RM.1860A 1600A	B2 PNL. 1655B2 BLDG. 999 RM.1860A 2000A		B2 PNL. 1654B2 BLDG. 997 RM.3210 1200A	A2 SPARE 1600A	
1655 MAIN	A3 SPACE	B3 SPACE	TIE BREAKER 1655 & 1654 3200A.	B3 PNL. 1654B3 BLDG. 998 RM. 2222 800A	A3 SPACE	1654 MAIN
	A4 PNL. 1655A4 BLDG. 999 RM. 1653 1600A	B4 PNL. 1655B4 BLDG. 999 RM. 1653 800A	SPACE	B4 SPACE	A4 PNL. 1654A4 BLDG. 998 RM. 1999 1600A	
3200A	1600A	800A		1600A	3200A	

Figure 13 illustrates the proper method of numbering circuit breakers in a double-ended switchgear.

15 March 2023

LLNL-MI-823076

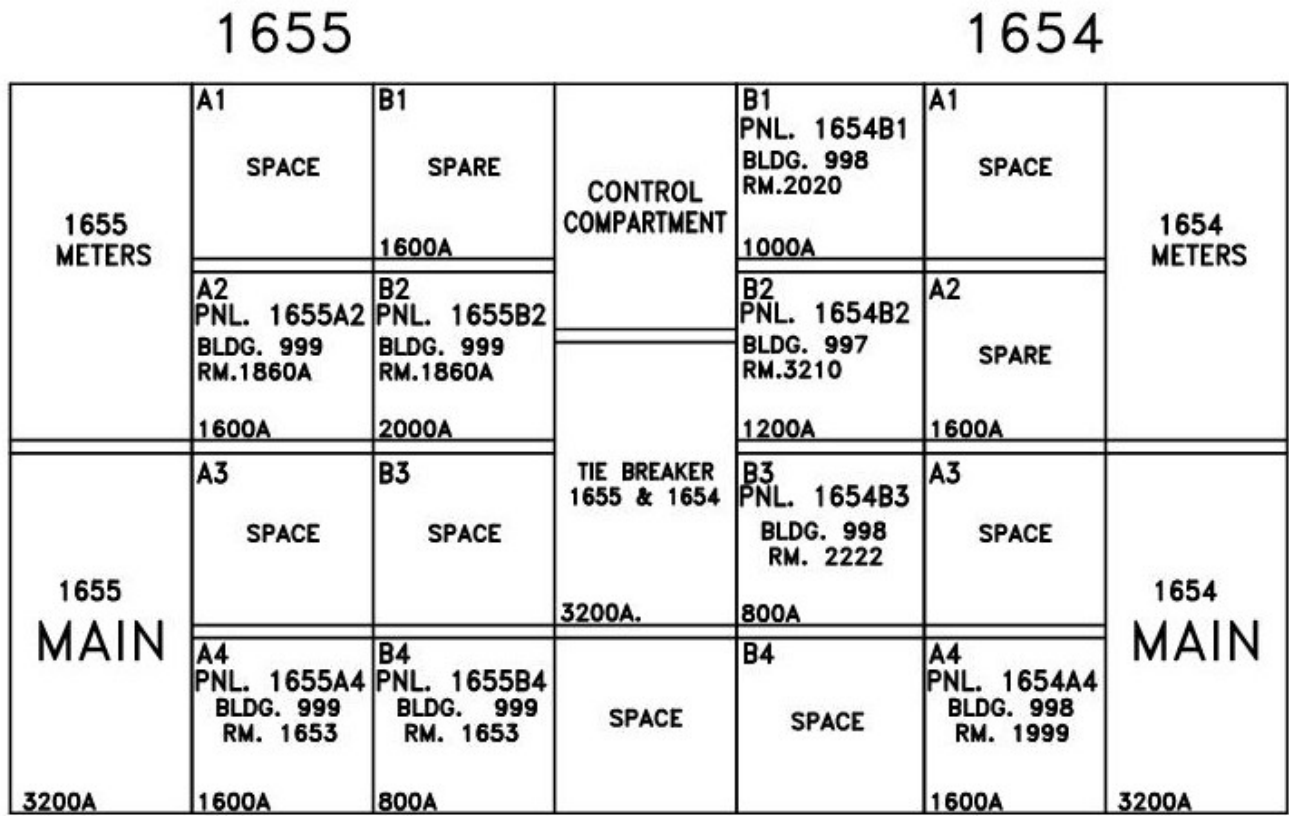

Figure 13. Switchgear

2.9 Plug-In Bus Duct Numbering

Bus duct plugs are numbered based upon their location relative to the power entry point on the bus. Figure 14 illustrates the proper method of numbering circuit breakers on a plug-in bus duct system. Where it is impractical to post schedules for a bus duct system, show all loads on the one-line drawings.

15 March 2023

LLNL-MI-823076

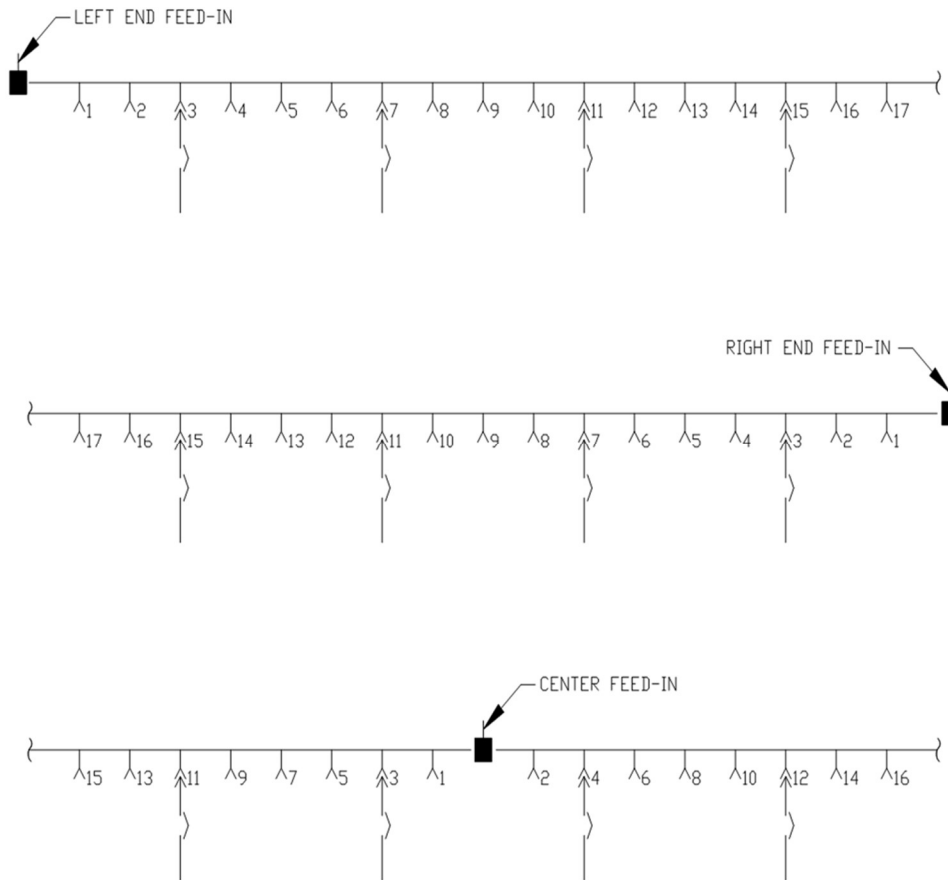

Figure 14. Plug-in bus duct

2.10 Site Lighting Numbering

Use the following the numbering schema for site lighting numbering and labels. Refer to Figure 15 for example labels.

$$\underline{ZZ} \underline{SLE} - \underline{XXX} - \underline{###} - \underline{Y}$$

ZZ = Site Designation. Select the appropriate code from the two listed below.

02 = Site 200

15 = Site 300

SLE = Site Lighting, Electrical. Static identifier; do not change.

XXX = Site Lighting Type. Select the appropriate code from the options listed below.

P#H = Pole lighting, where # = number of heads

W = Wall mounted

15 March 2023

LLNL-MI-823076

BD = Bollard

C = Canopy

F = Floodlight

= **Lighting Group Number**. If adding on to an existing circuit, use the existing group number assigned. If using a new site lighting circuit, CMSG field coordinators will assign a new group number.

Y = **Unique Group Identifier**. Unique numeric identifier for the individual luminaires (pole lights count as one no matter the number of heads) per group. CMSG field coordinators will assign based on availability. Identifiers may be out of sequence.

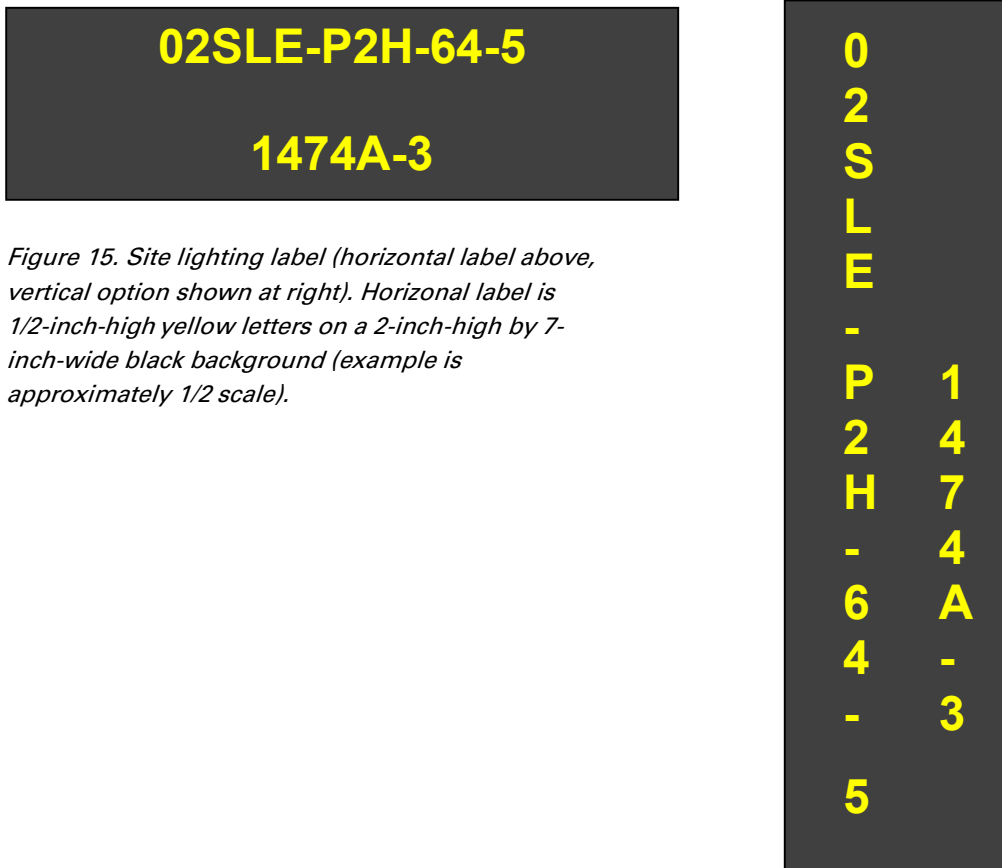

Figure 15. Site lighting label (horizontal label above, vertical option shown at right). Horizontal label is 1/2-inch-high yellow letters on a 2-inch-high by 7-inch-wide black background (example is approximately 1/2 scale).

3 EQUIPMENT LABELING

3.1 General

3.1.1 Each device is assigned a unique identification number by LLNL CMSG to facilitate computerized processing of inventory, preventive maintenance, and operational data.

15 March 2023

LLNL-MI-823076

3.1.2 Work described in this standard that is not specifically called out to be done by a subcontractor will be done by CMSG.

3.1.3 Conspicuously locate identification.

3.1.3.1 Use engraved two-layer laminated plastic plate or thermal-transfer labels with 7/8-inch-high minimum characters on colored background; see Figure 17.

3.1.3.2 Use smaller labels only when the equipment is too small for the standard size labels.

3.1.4 Color Coding

3.1.4.1 Normal power equipment is designated by yellow lettering on a black background.

3.1.4.2 Emergency power equipment is designated by black lettering on a yellow background and the use of the prefix "E" in the device name.

3.1.4.3 Limited and unlimited UPS powered equipment is designated by white lettering on a blue background and the use of the prefix "LU" or "EU" in the device name, respectively.

3.2 Switchgear, Switchboards, Panelboards, Motor Control Centers, Distribution Panels, and Emergency Power Panels:

3.2.1 Identify circuit number and voltage as shown on the drawings with a plate or thermal-transfer label (including "W/MAIN," if it has one). Size label 4 inches high by 7 inches wide with 7/8-inch-high letters.

3.2.2 Exceptions and Pre-existing Conditions:

3.2.2.1 Label new buildings and large remodeling projects that do not have previously labeled equipment in accordance with this standard.

3.2.2.2 More than one numbering system is currently in use at LLNL. Existing panels with labels and circuit-breaker numbers that differ from the current standard scheme, but have connected equipment and circuit breakers labeled correctly, may continue to use the existing numbering as sanctioned by the BEAHJ. Refer to figure 9 above.

3.2.2.3 Include documentation and correction of labels to either the established numbering system used in the area, approved by the CMSG or this

15 March 2023

LLNL-MI-823076

standard, for partial upgrades and retrofits that cause or discover a panel label or its connected equipment labels to conflict with each other.

Figures 16, 17, 18 and 19 illustrate the panel identification number, voltage, and if the panelboard has a main.



Figure 16. Distribution panel with main power source entry plate/label; 7/8-inch-high yellow letters on 4-inch high by 7-inch-wide black background (figure is approximately 1/2 scale)

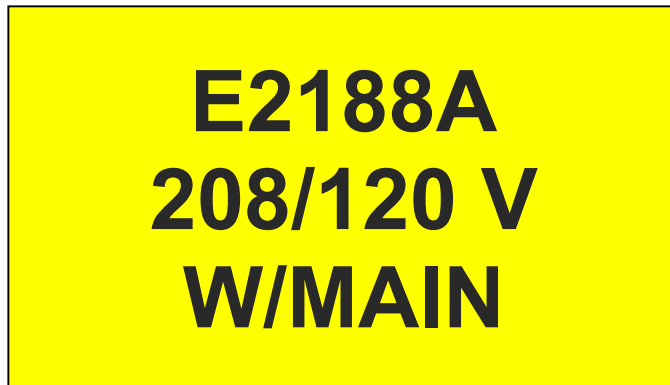

Figure 17. Distribution panel with main emergency power source entry plate/label; 7/8-inch-high black letters on 4-inch-high by 7-inch-wide yellow background (figure is approximately 1/2 scale)

15 March 2023

LLNL-MI-823076

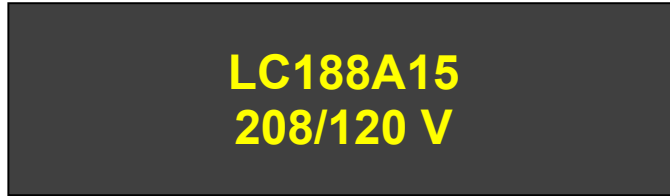

Figure 18. Load center panel plate/label with 1/2-inch-high yellow letters on a 2-inch-high by 7-inch-wide black background (figure is approximately 1/2 scale).



Figure 19. Distribution panel providing emergency uninterruptable power source (UPS) entry plate/label; 7/8-inch-high white letters on 4-inch-high by 7-inch-wide blue background (figure is approximately 1/2 scale)

3.3 Low-Voltage Transformers

- 3.3.1 Use a plate or thermal-transfer label sized 4 inches high with 7/8-inch-high letters as shown in figure 20.
- 3.3.2 First line is transformer number shown on the drawings.
- 3.3.3 Second line is primary circuit number.
- 3.3.4 Third line is primary and secondary voltages.



Figure 20. Transformer plate/label; 7/8-inch-high yellow letters on 4-inch high by 9-inch-wide black background (figure is approximately 1/2 scale). I&O is responsible for labeling high-voltage transformers (TH).

3.4 High-Voltage Transformers

- 3.4.1 Use a plate or thermal-transfer label sized 4 inches high with 7/8-inch-high letters as shown in figure 21
- 3.4.2 First line is transformer number shown on the drawings.
- 3.4.3 Second line is the base rating of the transformer.
- 3.4.4 Third line is secondary voltage.



Figure 21. High-voltage transformer label.

3.5 Receptacles, switches, and outlets

Identify by the circuit number shown on the drawings with thermal-transfer labels. Place the label on the plate cover if the device is wall-mounted; place on the device enclosure if it is not.

15 March 2023

LLNL-MI-823076

3.6 Utilization Equipment

Identify all drives, starters, disconnect switches, and control devices with a plate or thermal-transfer label. Match identification exactly to equipment legend noted on the drawings. Size label at least 2-1/4 inches high with 1/2-inch-high letters.

3.7 Mechanical Equipment

- 3.7.1 Prior to equipment being inspected and energized, provide and install temporary equipment labels that must be 7/8-inch letters, ***equipment numbering system*** must be as indicated in construction documents or original equipment replaced; plastic "Gravoply" laminate or thermal transfer labels must be Pink with Black characters for normal power and with white characters for emergency power until accepted and labeling corrected by I&O.

Refer to LLNL Facilities Standard PEL-M-230550, *Equipment Numbering*, for proper equipment numbering. Show the equipment number in the description section of the panel schedule for mechanical equipment.

3.8 Electrical hazard (arc flash and shock) Warning Labels

The I&O Systems and CMSG are responsible for labeling switchboards, switchgear, panelboards, industrial control panels, low voltage transformers, and motor control centers communicate electrical hazards to workers. Labels must be self-adhesive vinyl labels nominally four inches high and six inches high. The format for labels is per figure 22, below. A template (in SKM software) for this label is available from I&O Systems Engineering.

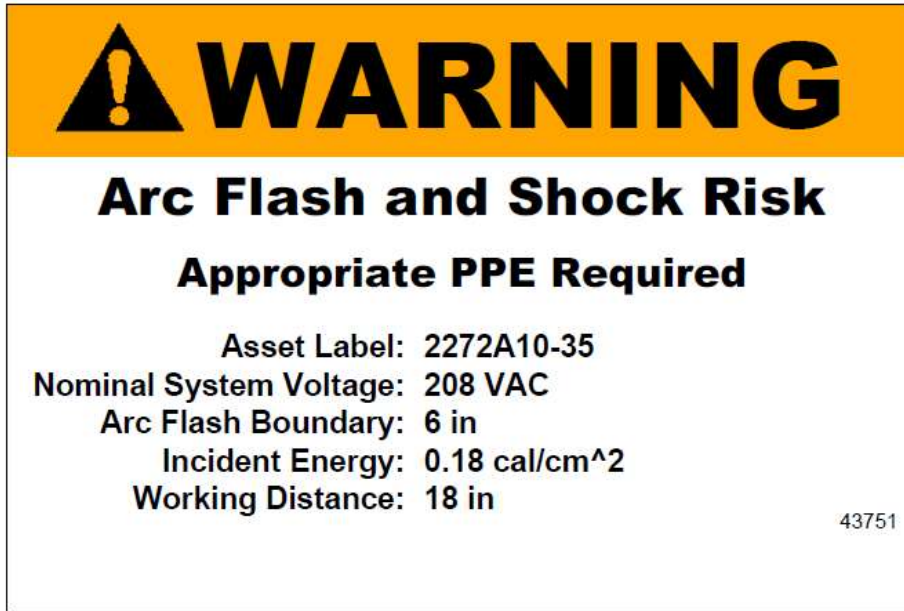

Figure 22. Arc flash and shock risk warning label.

3.9 Clear Working Space Labels

Using labels provided by CMSG, mark equipment likely to require examination, adjustment, servicing, or maintenance while energized reminding building occupants to maintain clear space as required by OSHA 1910.303. Use self-adhesive vinyl labels nominally four inches high and six inches high are used. The format for labels is per figure 23, below.



Figure 23. Electrical panel clearance label.

15 March 2023

LLNL-MI-823076

4 SCHEDULING

4.1 General

4.1.1 When completing panelboard schedules, keep the following points in mind (see figure 24 below):

- Completely fill the top and bottom portions of the schedule. Do not leave blank spaces.
- After the heading “Breaker Type,” list the exact type of breaker used in the panel.
- After listing all feeder breakers and spare breakers, show the remaining space available in the panelboard. Cross-out the portion of the schedule that exceeds the size of the panelboard.
- Generate a deficiency tag to the I&O electric shop when broken hardware is encountered on existing panels. If the electrical panel is new, the project is responsible for acquiring replacement parts.

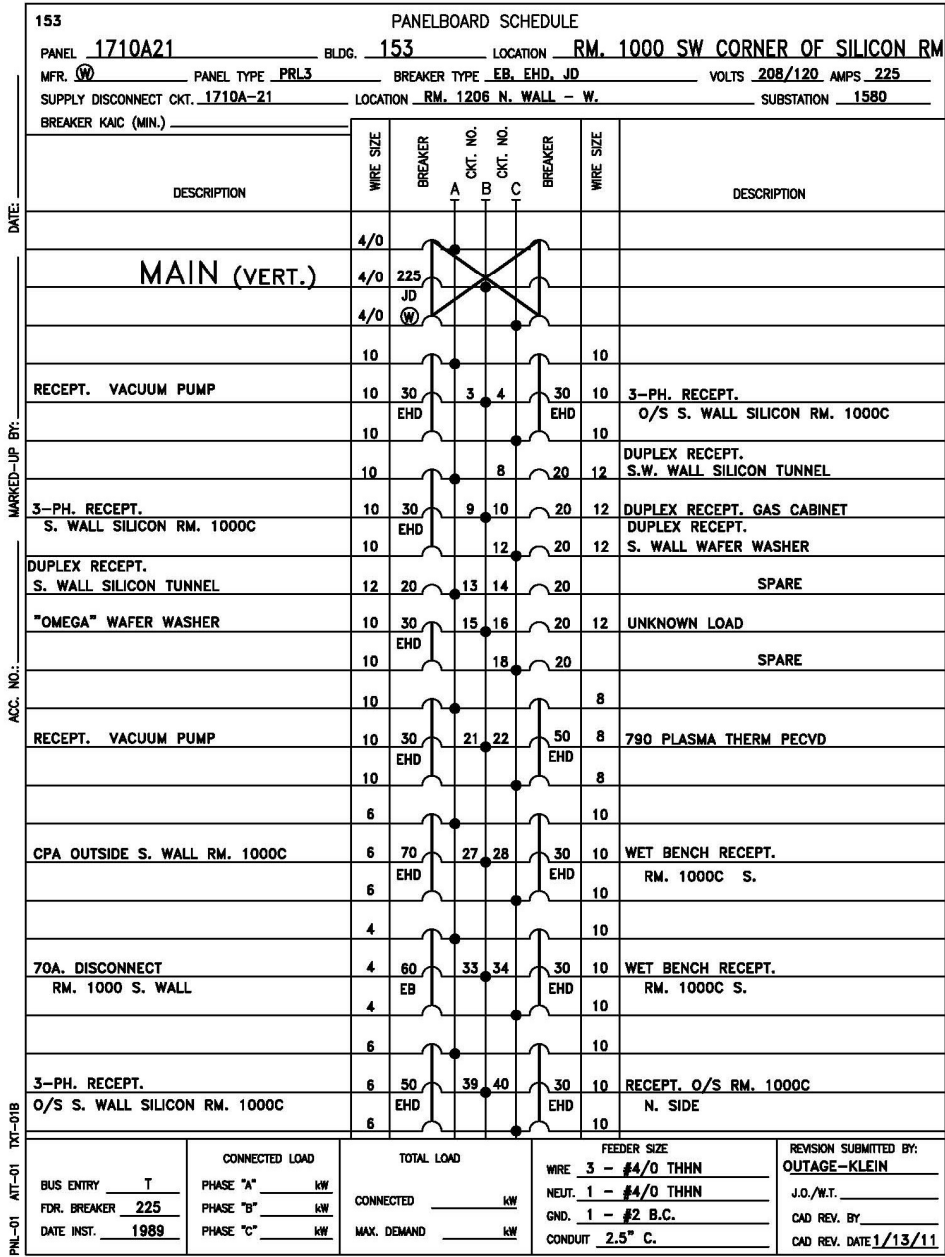

Figure 24. Completed panelboard schedule, typical.

4.2 Schedule Changes

4.2.1 Revise, update, and archive schedules for projects requiring changes to an existing panel.

15 March 2023

LLNL-MI-823076

4.2.2 The installer is responsible for field updating the electrical panel schedule when modifying an electrical panel. Make three copies of the revised panel schedule, marking new entries in green and deletions in red. Leave two copies in the panel schedule holder and send one copy of the marked-up panel schedule to the CMSG.

4.2.3 CMSG will update and archive the panel schedule and post 2 copies in the field.

4.3 Schedule Implementation

4.3.1 Schedule Holder: Configuration Management Services Group provides the schedule holders if needed.

4.3.2 Work order installations (including I&O electricians, machine tool services, and supplemental labor):

4.3.2.1 The designer or crafts person must comply with sections 3.1 through 4.2.

4.3.2.2 The crafts will perform the work, put two copies of the revised panel schedule in the panel schedule holder, and send one copy to CMSG (mail code: L-602), with a valid work order number. Do not close out the work order until the panel schedule changes have been made and put back in the panel.

4.3.2.3 CMSG will update the original, and stamp and distribute the following copies:

No. of Copies	Distribution
2	"Panel Copy" to the power panel
1	"FPOC" to the Facility Point of Contact
1	Electrical panelboard repository (CMSG)

4.3.2.4 CMSG will update the one-line diagram and panel location drawings and send an electronic copy to the PMO Documentation and Technical Services PMO-TAP@llnl.gov for distribution and archive.

4.3.3 Purchase Order

4.3.3.1 The designer must comply with section 4.2, paragraphs 4.2.1 and 4.2.2, and include the panel schedule copies with the purchase order. The copies will be removed from the package by LLNL Supply Chain

15 March 2023

LLNL-MI-823076

Management department and sent to the Project Management Office (PMO).

4.3.3.2 The PMO holds the panel schedules until the final acceptance.

End of Standard